

# ***PARTS CATALOGUE***

## **DISK HARROWS**

**GICM 12/14/16/18/20 DISCS - MECHANICAL**

**Code: 0501092604**



**Series: S-0805**

**Rev.: 00**

**Date Rev.: OUTUBRO/2019**

**ORIGINAL PARTS  
CIVEMASA**

***civemasa***

# PRODUCTS

Code	Description
0121050001	GICM 12 MEC 26 X 6,0 R 61360029 S-0805
0121050006	GICM 12 MEC 28 X 6,0 R 61360074 S-0805
0121050002	GICM 14 MEC 26 X 6,0 R 61360038 S-0805
0121050007	GICM 14 MEC 28 X 6,0 R 61360019 S-0805
0121050003	GICM 16 MEC 26 X 6,0 R 61360047 S-0805
0121050008	GICM 16 MEC 28 X 6,0 R 61360083 S-0805
0121050004	GICM 18 MEC 26 X 6,0 R 61360056 S-0805
0121050009	GICM 18 MEC 28 X 6,0 R 61360092 S-0805
0121050005	GICM 20 MEC 26 X 6,0 R 61360065 S-0805
0121050010	GICM 20 MEC 28 X 6,0 R 61360101 S-0805

## ATTENTION: **IMPORTANT**

*CIVEMASA RESERVES THE RIGHT AT ANY TIME TO MAKE IMPROVEMENTS IN THE DESIGN, MATERIAL OR SPECIFICATIONS OF MACHINERY, EQUIPMENT OR PARTS WITHOUT THEREBY BECOMING LIABLE TO MAKE SIMILAR CHANGES IN MACHINERY, EQUIPMENT OR PARTS PREVIOUSLY SOLD.*

# INDEX

0909094213	FRAME ASSY	.....	1
0501042816	ASSY TRACTION BAR	.....	2
0501051632	RIGHT STUB SHAFT & HUB ASSY	.....	3
0501051633	LEFT STUB SHAFT & HUB ASSY	.....	4
0501051142	CARRYING WHEEL HUB	.....	5
0503060094	WHEEL AND TIRE ASSY	.....	6
0501047858	ADJUSTMENT LEVER ASSY	.....	7
0909094217	ASSY ADHESIVE LABELS	.....	8
0909094216	12/14/16/18/20D - DISC GANG SECTION	.....	9
0501046925	262 X 1-5/8" OIL BATH BRG ASSY,FG	.....	10

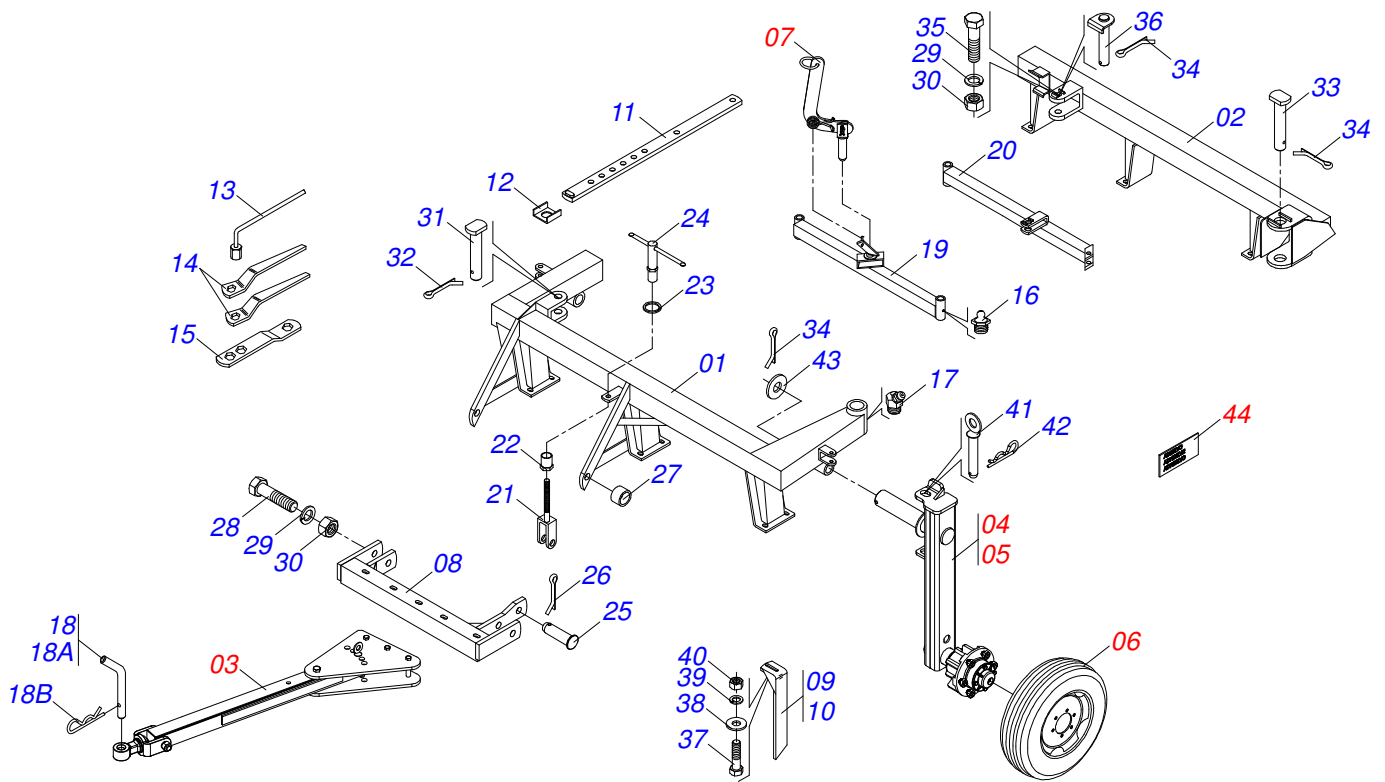

Item	Code	Description	See page	12	14	16	18	20
01	0521064623	FRONT FRAME GICM 12 MECHANICAL		01	00	00	00	00
01.	0521064625	FRONT FRAME GICM 14 MECHANICAL		00	01	00	00	00
01..	0521064627	FRONT FRAME GICM 16 MECHANICAL		00	00	01	00	00
01...	0521064629	FRONT FRAME GICM 18 MECHANICAL		00	00	00	01	00
01....	0521064631	FRONT FRAME GICM 20 MECHANICAL		00	00	00	00	01
02	0521064624	REAR FRAME GICM 12 MECHANICAL		01	00	00	00	00
02.	0521064626	REAR FRAME GICM 14 MECHANICAL		00	01	00	00	00
02..	0521064628	REAR FRAME GICM 16 MECHANICAL		00	00	01	00	00
02...	0521064630	REAR FRAME GICM 18 MECHANICAL		00	00	00	01	00
02....	0521064632	REAR FRAME GICM 20 MECHANICAL		00	00	00	00	01
03	0501042816	ASSY TRACTION BAR	2	01	01	01	01	01
04	0501051632	RIGHT STUB SHAFT & HUB ASSY	3	01	01	01	01	01
05	0501051633	LEFT STUB SHAFT & HUB ASSY	4	01	01	01	01	01
06	0503060094	WHEEL AND TIRE ASSY	6	02	02	02	02	02
07	0501047858	ADJUSTMENT LEVER ASSY	7	01	01	01	01	01
08	0501065547	OFFSET BAR		01	00	00	00	00
08.	0501065548	OFFSET BAR		00	00	01	00	00
08..	0501065549	OFFSET BAR		00	01	00	01	01
09	0501064168	REAR SCRAPER		03	04	04	04	05
10	0501064167	REAR SCRAPER		03	04	04	04	05
11	0501064196	ADJUSTMENT BAR		01	00	00	00	00
11.	0501064198	ADJUSTMENT BAR		00	01	00	00	00
11..	0501064197	38" ADJUSTMENT BAR		00	00	01	01	01
12	0501011649	U 1.2" X 3.1" X 3/16" BAR		01	01	01	01	01
13	0503016140	3/4" WRENCH CABLE CYLINDRICAL		01	01	01	01	01
14	0501011431	1-3/4" GANG BOLT WRENCH		02	02	02	02	02
15	0511018451	5/8" X 3/4" X 1" UNIVERSAL		01	01	01	01	01
16	0503010002	1800 GREASE FITTING		02	02	02	05	05
17	0503010003	1845 GREASE FITTING		01	01	01	01	01
18	0501040343	DRAWBOLT ASSY		01	01	01	01	01
18A	0501010523	DRAWBOLT		01	01	01	01	01

Item	Code	Description	See page	12	14	16	18	20
18B	0503031035	HAIR PIN		01	01	01	01	01
19	0501062506	FRONT STABILIZER BAR		00	00	01	01	01
20	0501062508	REAR STABILIZER BAR		00	00	01	01	01
21	0501060201	REGULATOR BOLT		01	01	01	01	01
22	0501068984	BUSHING WITH NUT		01	01	01	01	01
23	0501014509	FLAT WASHER		01	01	01	01	01
24	0501110265	BUSHING WITH CRANK		01	01	01	01	01
25	0521010571	COUPLING SHAFT		01	01	01	01	01
26	0503010571	1/4" X 1.1/2 COTTERPIN		01	01	01	01	01
27	0511019921	1.3" X 0.1" X 1" SLEEVE		02	02	02	02	02
28	0501011547	1" X 4-1/2" BOLT		02	02	02	02	02
29	0503010012	1" SPRING WASHER		03	03	03	03	03
30	0501010059	1.5/8 NUT		03	03	03	03	03
31	0521010644	1.5" X 8.4" COUPLING SHAFT		00	00	01	01	01
32	0503010534	3/8 X 2-1/2 COTTERPIN		00	00	01	01	01
33	0501065487	2.4" X 123" COUPLING SHAFT		01	01	01	01	01
34	0503010073	3/8 X 3-1/2 COTTERPIN		04	04	04	04	04
35	0503011432	1" X 4" BOLT		01	01	00	00	00
36	0501062195	37,5 X 182 - JUNCTION SHAFT		01	01	01	01	01
37	0503011082	C1/2" X 1.3/4" BOLT		12	16	16	16	20
38	0511017302	FLAT WASHER		12	16	16	16	20
39	0503010019	1/2" SPRING WASHER		12	16	16	16	20
40	0503010060	1/2" NUT		12	16	16	16	20
41	0501068993	0.9" X 5.5" COUPLING SHAFT		02	02	02	02	02
42	0503030168	HAIR PIN		02	02	02	02	02
43	0501010246	FLAT WASHER		02	02	02	02	02
44	0909094217	ASSY ADHESIVE LABELS	8	01	01	01	01	01

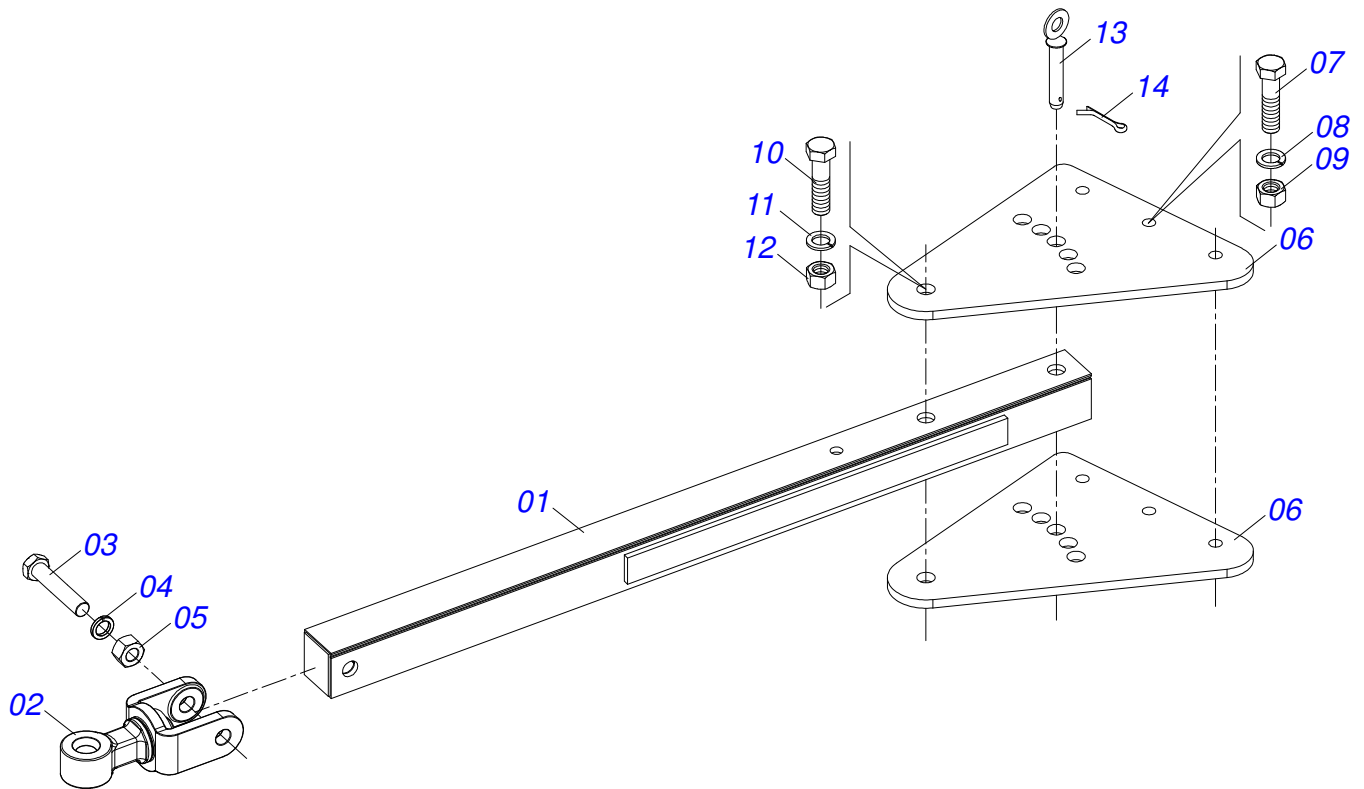

Item	Code	Description	See page	QT
01	0501060188	DRAWBAR ASSY		01
02	0521061775	TRACTOR HITCH		01
03	0501010060	1" X 6-1/2" BOLT		01
04	0503011438	SPRING WASHER		01
05	0501010059	1.5/8 NUT		01
06	0501010241	UPPER /LOWER PLATE		02
07	0503011198	C3/4" X 6" BOLT		03
08	0503011442	3/4" SPRING WASHER		03
09	0503010014	3/4" NUT		03
10	0501010191	1" X 6" BOLT		01
11	0503011438	SPRING WASHER		01
12	0501010059	1.5/8 NUT		01
13	0501068993	0.9" X 5.5" COUPLING SHAFT		01
14	0503010571	1/4" X 1.1/2 COTTERPIN		01

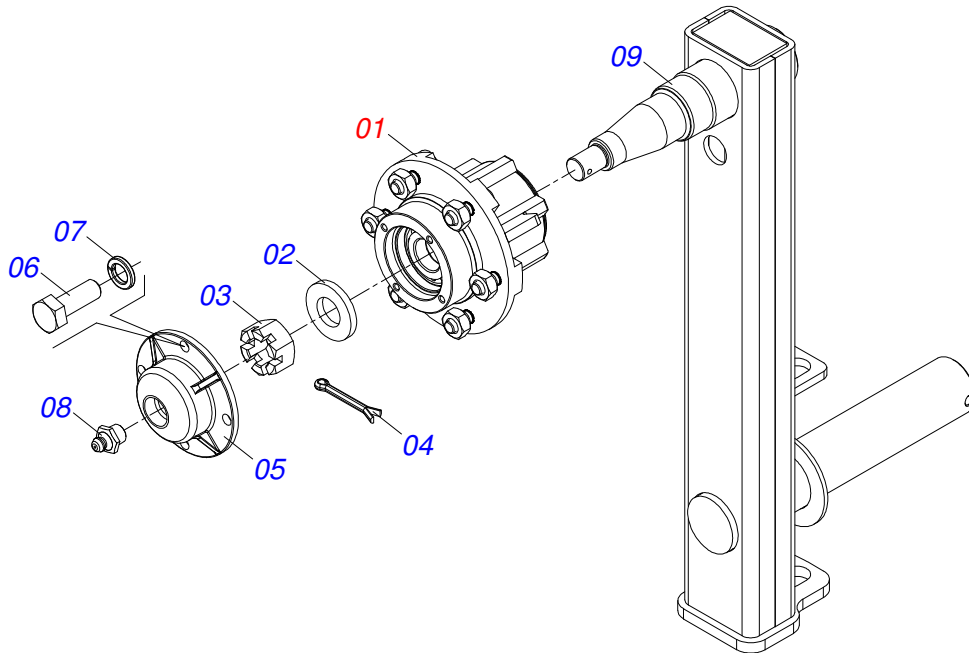

Item	Code	Description	See page	QT
01	0501051142	CARRYING WHEEL HUB	5	01
02	0501016545	FLAT WASHER		01
03	0503030009	1" CASTLE NUT		01
04	0503010018	5/32 X 1-1/2 COTTERPIN		01
05	0502020591	PROTECCION COVER		01
06	0503010358	5/16" X 5/8" BOLT		04
07	0503011444	SPRING WASHER		04
08	0503010002	1800 GREASE FITTING		01
09	0501069088	RIGHT CARRYING-WHEELS SUPPORT		01

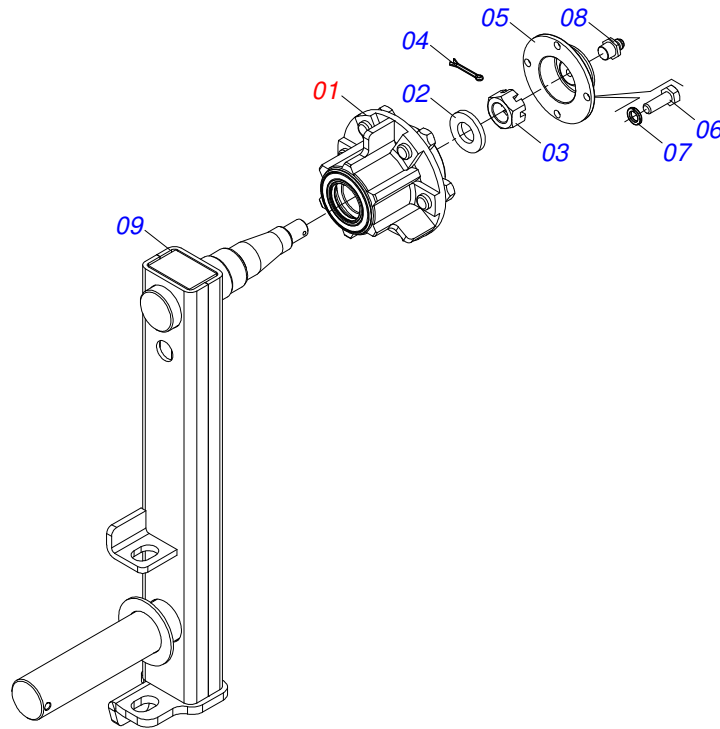

Item	Code	Description	See page	QT
01	0501051142	CARRYING WHEEL HUB	5	01
02	0501016545	FLAT WASHER		01
03	0503030009	1" CASTLE NUT		01
04	0503010018	5/32 X 1-1/2 COTTERPIN		01
05	0502020591	PROTECCION COVER		01
06	0503010358	5/16" X 5/8" BOLT		04
07	0503011444	SPRING WASHER		04
08	0503010002	1800 GREASE FITTING		01
09	0501069089	LEFT CARRYING-WHEELS SUPPORT		01



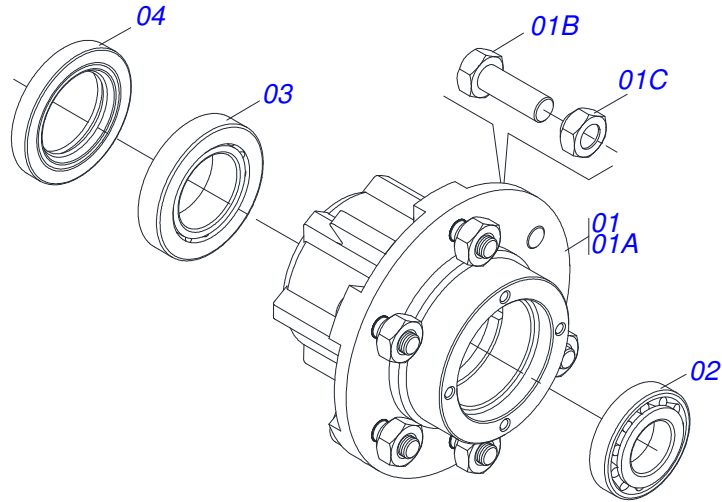

Item	Code	Description	See page	QT
01	0501110728	WHEEL HUB		01
01A	0502011121	CARRYING WHEEL HUB		01
01B	0501010127	9/16" X 1-7/8" LUG BOLT		06
01C	0503010035	9/16" CONIC NUT		06
02	0503010037	30207 ROLLER BEARING		01
03	0503010006	32210 ROLLER BEARING		01
04	0503012928	SEAL		01

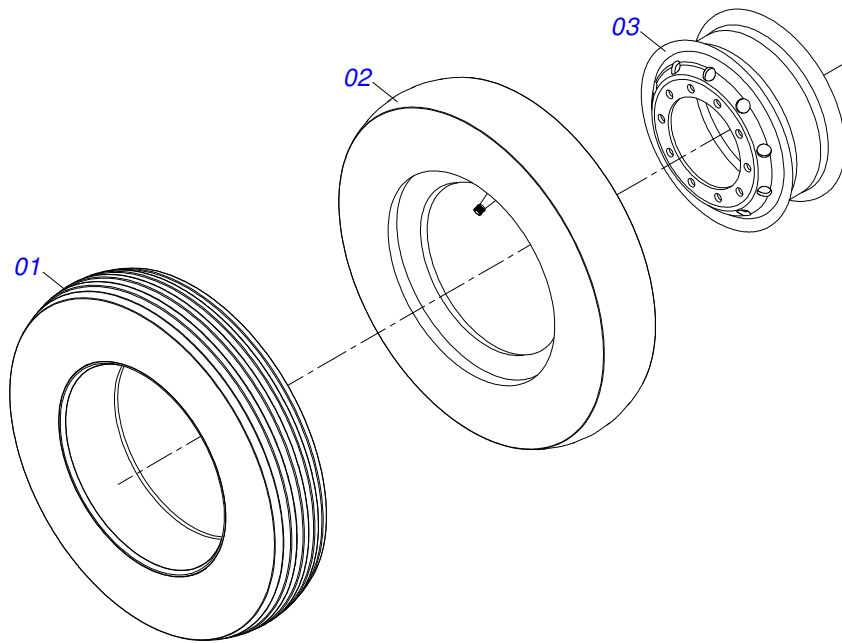

Item	Code	Description	See page	QT
01	0503010065	CANVAS TIRE		01
02	0503010068	6.00 X 16 INNER TIRE		01
03	0503010894	0.2"X0.6"X4.6"X6F0.6"X6" WHEEL		01

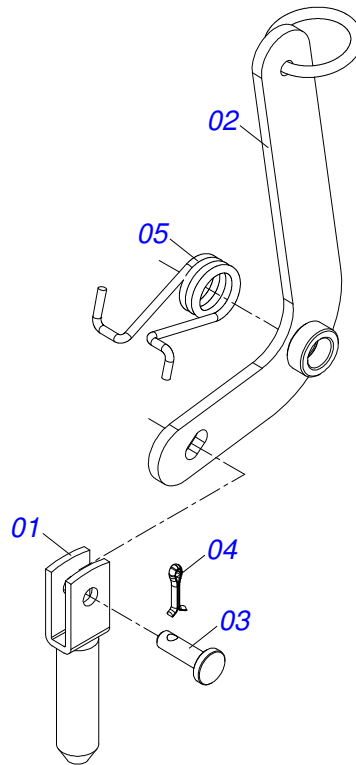

Item	Code	Description	See page	QT
01	0501060185	ADJUSTMENT LOCK		01
02	0501068981	ADJUSTMENT LEVER		01
03	0521010624	0.4" X 1.5" COUPLING SHAFT		01
04	0503010071	3/16" X 1" COTTERPIN		01
05	0503030025	1.4" X 0.2" TORSION SPRING		01

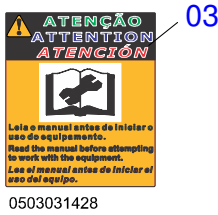
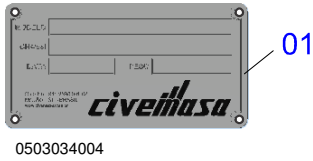

Item	Code	Description	See page	QT
01	0503034004	ALUMINUM IDENTIFICATION LABEL		01
02	0503010001	RIVET POP		04
03	0503031428	ADHESIVE LABEL ATTENTION		01
04	0503033647	APPROVED BADGE		01
05	0503031739	ADHESIVE LABEL DANGER		01
06	0503033905	ADHESIVE		02
07	0503033245	EMBLEM		02

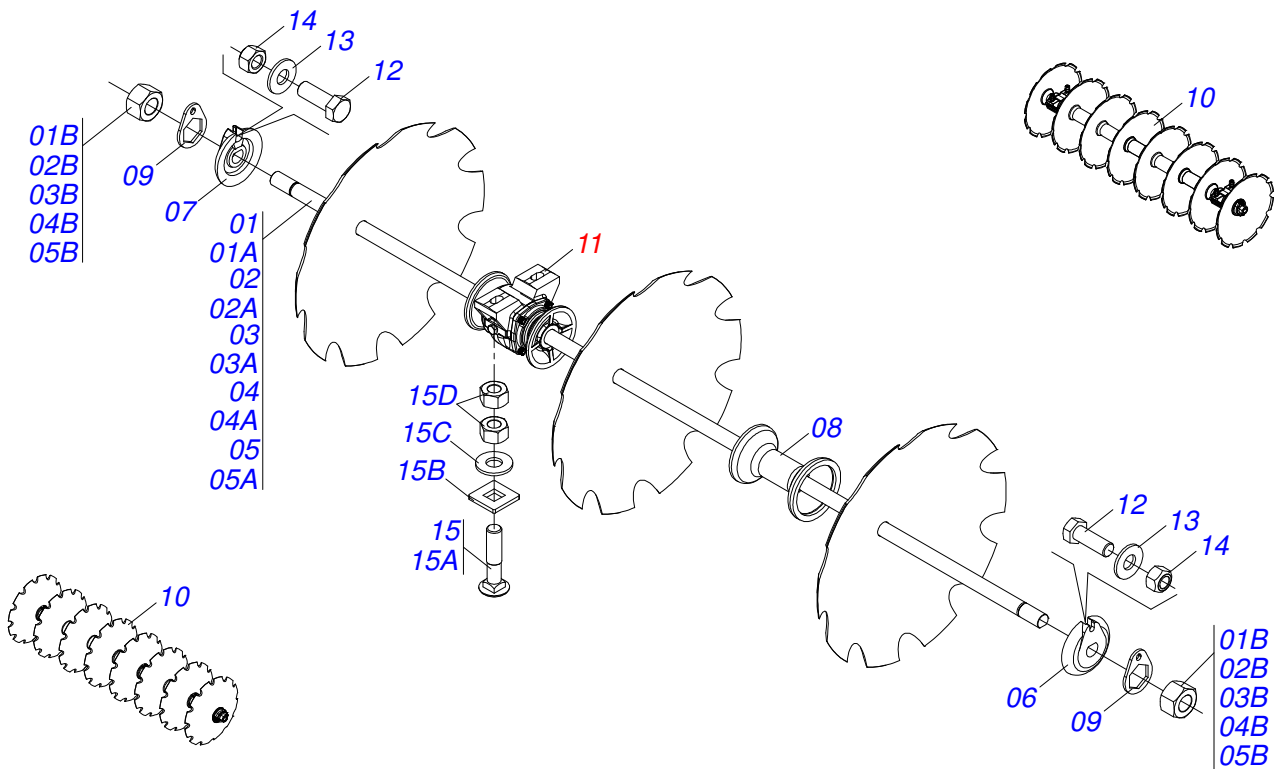

Item	Code	Description	See page	12	14	16	18	20
01	0501046856	1-5/8" X 59" AXLE WITH NUTS 2-3/4		02	00	00	00	00
01A	0501019012	1-5/8" X 59" AXLE		02	00	00	00	00
01B	0502040640	1.5/8" 2.3/4" NUT		04	00	00	00	00
02	0501046859	1-5/8" X 70" AXLE WITH NUTS 2-3/4"		00	02	00	00	00
02A	0501015631	1-5/8" X 70" AXLE		00	02	00	00	00
02B	0502040640	1.5/8" 2.3/4" NUT		00	04	00	00	00
03	0501046861	1-5/8" X 80" AXLE WITH NUTS 2-3/4"		00	00	02	00	00
03A	0501019015	1-5/8 X 80" AXLE		00	00	02	00	00
03B	0502040640	1.5/8" 2.3/4" NUT		00	00	04	00	00
04	0501046811	1-5/8" X 38"- AXLE WITH NUTS 2-3/4		00	00	00	02	00
04A	0501019013	1-5/8" X 38" AXLE		00	00	00	02	00
04B	0502040640	1.5/8" 2.3/4" NUT		00	00	00	04	00
05	0501046854	1-5/8" X 48" AXLE WITH NUTS 2-3/4		00	00	00	02	04
05A	0501019016	1-5/8 X 48" AXLE		00	00	00	02	04
05B	0502040640	1.5/8" 2.3/4" NUT		00	00	00	04	08
06	0502011047	1-5/8" INNER AXLE WASHER		02	02	02	04	04
07	0502011048	1-5/8" EXTERNAL AXLE WASHER		02	02	02	04	04
08	0502010703	10.35" 1-5/8" SPACER		06	08	08	06	08
09	0511014339	1-5/8" 2.8" NUT LOCK		04	04	04	08	08
10	0602037004	28" X 0.2" NOTCHED DISC BLADE		12	14	16	18	20
10.	0602033005	26" X 0.2" NOTCHED DISC BLADE		12	14	16	18	20
11	0501046925	262 X 1-5/8" OIL BATH BRG ASSY,FG	10	04	02	06	08	08
12	0503011267	5/8" X 1.1/2" BOLT		04	04	04	08	08
13	0501012140	FLAT WASHER		04	04	04	08	08
14	0503012412	HEX SELF ADJUSTING NUT 5/8 UNC S		04	04	04	08	08
15	0511040034	3/4" X 3-1/4" BOLT ASSY		08	08	12	16	16
15A	0501017303	3/4" X 3-1/4" BOLT		08	08	12	16	16
15B	0501010949	3/4" SQUARE WASHER		08	08	12	16	16
15C	0501010322	FLAT WASHER		08	08	12	16	16
15D	0503010014	3/4" NUT		16	16	24	32	32

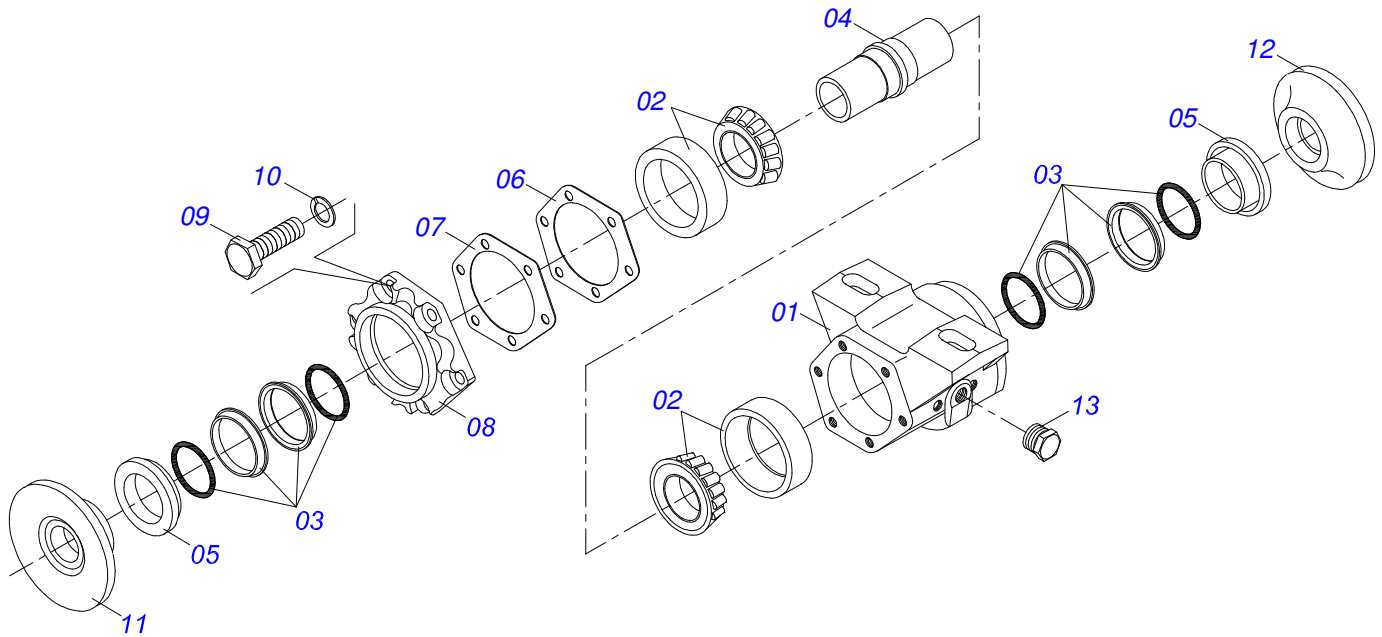

Item	Code	Description	See page	QT
01	0502020481	HOUSING DM		01
02	0503010005	32212 ROLLER BEARING		02
03	0503030027	DUO-CONE SEAL		02
04	0502010900	BEARING AXLE		01
05	0502010735	SEAL RETAINER		02
06	0503030030	5.6" X 4.4" X 0.01" GASKET		02
07	0503030685	5.5" X 4.4" X 0.003" GASKET		02
08	0502020161	WEAR PLATE BEARING		01
09	0503010237	3/8" X 1" BOLT		06
10	0503011443	SPRING WASHER		06
11	0502040239	OUTER FLANGE		01
12	0502040240	INNER FLANGE		01
13	0503010856	OIL PLUG		01





email: [civemasa@civemasa.com.br](mailto:civemasa@civemasa.com.br)

[www.civemasa.com.br](http://www.civemasa.com.br)

Phone: +55 16.3382.8222

Fax: +55 16.3382.8355

## MARCHESAN IMPLEMENTOS E MÁQUINAS AGRÍCOLAS "TATU" S.A.

Av. Marchesan, 1979 - Post Office box, 131 - Cep 15994-900 - Matão - Sp - Brasil

CNPJ 52.311.289/0001-63 | Inst. Est.441.000.151.114

**Technical Publications: Elaboration**

ALESSANDRA PATRICIA KAWAHARA CARRILI

**Technical Publications: Revision**

ALESSANDRA PATRICIA KAWAHARA CARRILI

Contact Catálogo:

E-mail = [jgaspari@marchesan.com.br](mailto:jgaspari@marchesan.com.br)

ORIGINAIS PARTS  
CIVEMASA

**civemasa**