

**DISK HARROWS**

**GVMF 28D**  
**GVMF 28D**

**Code:** 0501090670  
**Series:** S-1215  
**Revision:** 00  
**Revision Date:** MAY/2024

**PARTS**  
**CATALOGUE**

***CIVEMASA***

An orange rectangular bar is positioned at the top left of the page, above the "PRODUCTS" heading.

# PRODUCTS

Code	Working Width	Description
0120040045		GVMF 28 X 34 X 9,0 DR 400/60 S-1215

### ATTENTION: IMPORTANT

CIVEMASA reserves the right to improve and/or modify the technical features of its products, without obligation to do the same with those products already sold and without prior knowledge of the dealer or the customer. The photos are only illustrative.

# INDEX

0909093126	FRAME ASSY	.....	1
0909093264	HYDRÁULIC CIRCUIT - 28D	.....	2
0531041451	HYDRAULIC CYLINDER 53,98 X 101,6 X 728 X 400	.....	3
0501053834	MALE QUICK COUPLER	.....	4
0511050262	DRAWBAR ASSEMBLY	.....	5
0511048088	DRAWBAR JACK	.....	6
0501055850	CARRYNG WHEEL HUB ASSEMBLY ASSY	.....	7
0503061868	400/60 WHEEL WITH TIRE	.....	8
0909093283	DISC GANG SET	.....	9
0501048557	BEARING OIL	.....	10

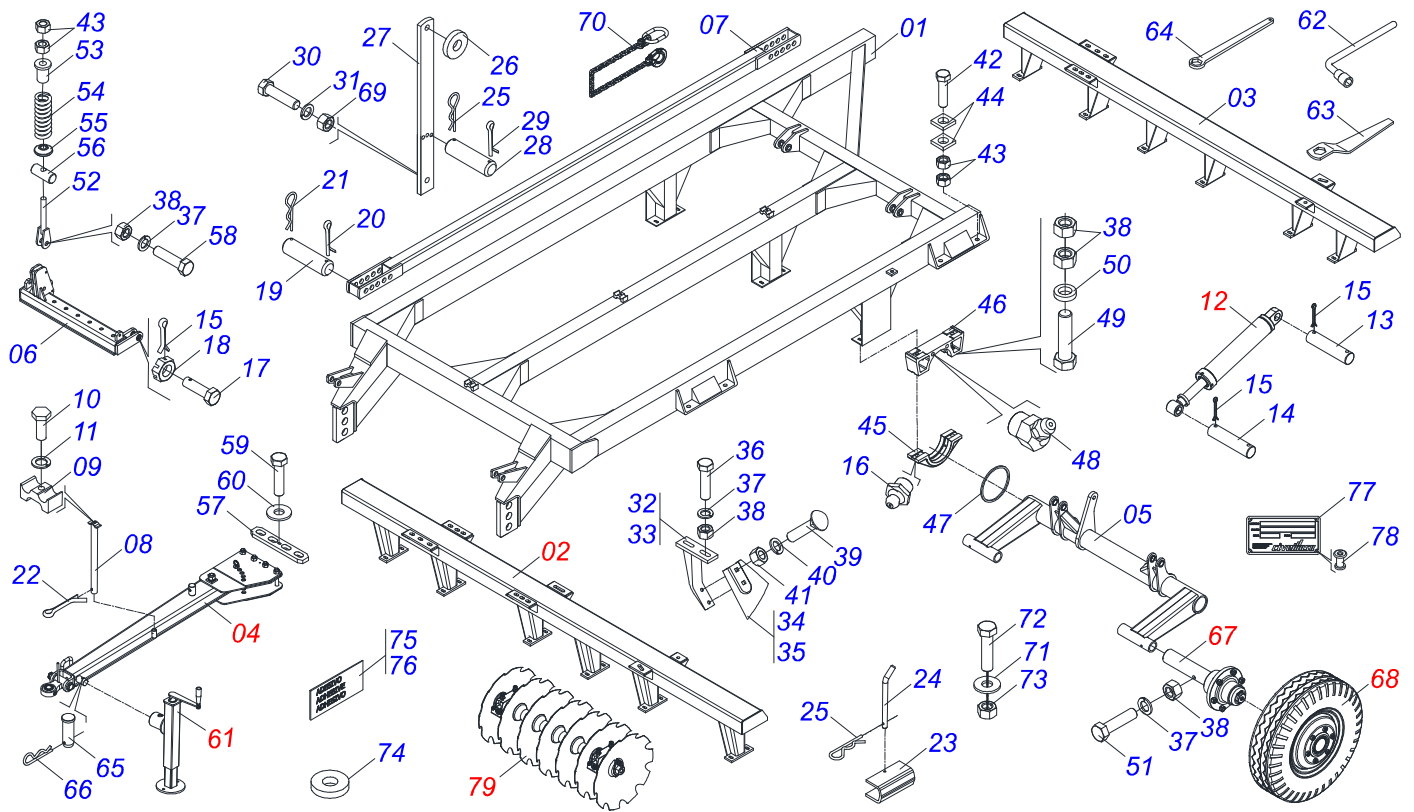

Item	Code	Description	See page	QT
01	0511060230	FRAME		01
02	0511062256	FRONT FRAME		01
03	0511062257	REAR FRAME		01
04	0511050262	DRAWBAR ASSEMBLY	5	01
05	0521066761	CARRYING-WHEELS		01
06	0511060231	DRAWBAR ASSY		01
07	0511060232	STABILIZER BAR		01
08	0511060205	SUPPORT HOSE CNS 20104N		01
09	0502012702	BODY SUPPORT CLAMP		04
10	0503012555	7/16" UNC X 2" CS RT G.7 ZN SCREW		04
11	0503010180	7/16" SPRING WASHER		04
12		HYDRÁULIC CIRCUIT - 28D	2	
13	0521013706	HEADLESS PIN		02
14	0591019956	44,45 X 168 HEADLESS PIN		02
15	0503010010	1/4" X 2.1/2" SPLIT PIN		10
16	0503010002	1800 GREASE FITTING		10
17	0521013843	BARRA DRAW BOLT		02
18	0503013026	1.1/4" CASTLE NUT		02
19	0521013776	HEADLESS CLEVIS PIN		02
20	0503010038	3/16" X 2" SPLIT PIN		02
21	0503031470	TM 251 X 4,0 STAPLE		02
22	0503012215	5/16" X 2.1/2" SPLIT PIN		01
23	0591018207	LOCK FOR TRANSPORT		02
24	0541016844	FIXER LOCK		02
25	0503031464	TM 211 X 3,0 STAPLE		03
26	0521013818	STRENGTHENING GL 41005 3281218		04
27	0521013814	1 U BOLT OF THE SUSPENSION TOWER		01
28	0521013812	HEADLESS CLEVIS PIN		01
29	0503010362	1/8" X 1.1/4" SPLIT PIN		01
30	0503012226	1-1/4" X 4" BOLT		01
31	0503010070	SPRING WASHER		01
32	0511060138	FRONT CLEANER SUPPORT		14

Item	Code	Description	See page	QT
33	0511060139	REAR CLEANER SUPPORT		14
34	0521013678	FRONT CLEANER		14
35	0521013679	REAR CLEANER		14
36	0503012180	FRENCH 3/4" X 2 BOLT		56
37	0503010023	3/4" SPRING WASHER		58
38	0503012183	SNC 3/4" ZIN 1K03097 NUT		68
39	0503012195	5/8" NUT		56
40	0503010027	5/8 SPRING WASHER		60
41	0503010013	5/8 UNC G.5 ZN HEX NUT		56
42	0503012257	1" X 4-1/4" BOLT		10
43	0503012182	1" NUT		24
44	0521013709	REINFORCING WASHER		20
45	0502011724	INF BEARING SEMI		03
46	0502011725	UPPER BEARING SEMI		03
47	0503012222	FELT RING		06
48	0503010003	1845 GREASE FITTING		06
49	0511016281	3/4" X 8" BOLT		06
50	0521013710	WASHER SEMIMAN		06
51	0503011084	3/4" X 5" BOLT		02
52	0511060124	SPINDLE ASSEMBLY		02
53	0502011582	SPINDLE GUIDE		02
54	0503031460	SPRING		02
55	0521013760	SPRING SUPPORT		02
56	0521013759	PIN SPINDLE GUIDE		02
57	0521013774	LOCK		01
58	0501010500	3/4" X 3" BOLT		02
59	0501010108	5/8" X 1" BOLT		01
60	0501012140	FLAT WASHER 16,50 X 40 X 4,00 ZN		01
61	0511048088	DRAWBAR JACK	6	01
62	0503018438	1" WRENCH CYLINDRICAL HEX		01
63	0501011431	1-3/4" GANG BOLT WRENCH		02
64	0531013656	WRENGH		01
65	0561014251	COUPLING SHAFT		01
66	0503030285	HITCH PIN CLIP		02
67	0501055850	CARRYNG WHEEL HUB ASSEMBLY ASSY	7	02
68	0503061868	400/60 WHEEL WITH TIRE	8	02
69	0503012181	1.1/4" NUT		01
70	0503013150	1300 X 3/8" CHAIN		01
71	0501010322	20,50 X 46 X 4,00 ZN FLAT WASHER		02
72	0501010500	3/4" X 3" BOLT		02
73	0503011255	3/4" LOCK NUT		02
74	0503013171	SEALING 1/2" X 10M 1J51066		01
75	0503031428	ATTENTION READ MANUAL DECAL		01
75.	0503033038	DANGER DECAL		02
75..	0503031738	WARNING DECAL		01
76	0503033434	ADHESIVE		02
76.	0503033647	APPROVED DECAL		01
76..	0503031739	DANGER DECAL		01
76...	0503034355	EMBLEM		02
77	0503034004	ALUMINUM IDENTIFICATION DECAL		01
78	0503010001	RIVET 3,2 X 5,5		04
79		DISC GANG SET	9	

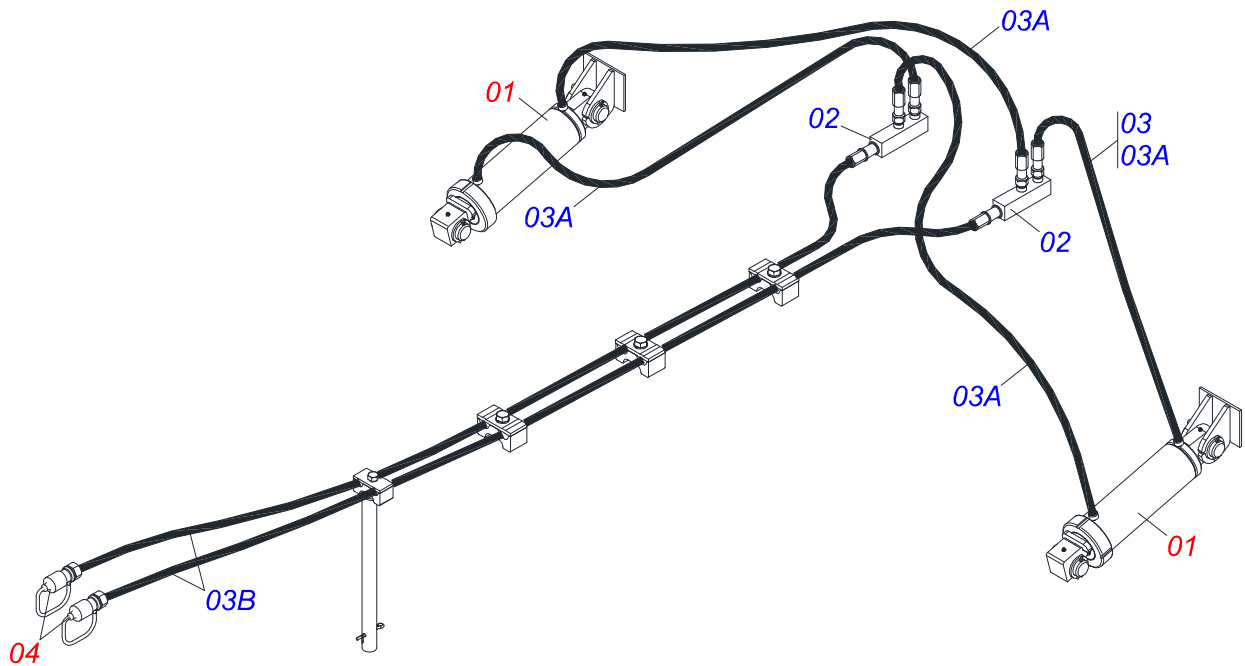

Item	Code	Description	See page	QT
01	0531041451	HYDRAULIC CYLINDER 53,98 X 101,6 X 728 X 400	3	02
02	0501074276	TERMINAL CONNECTION		02
03	0501053213	HOSE KIT		01
03A	0501080852	HOSE 3/8" X 1500 TR-TM		04
03B	0501080815	HOSE 3/8 X 8300 TM-TM		02
04	0501053834	MALE QUICK COUPLER	4	02

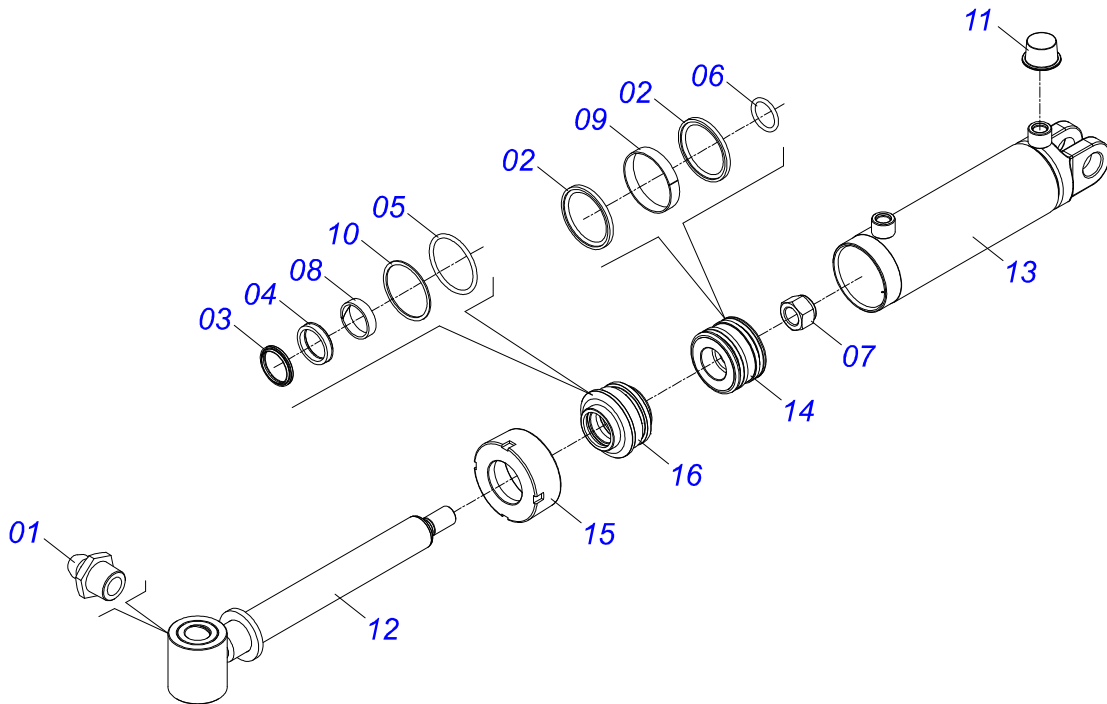

Item	Code	Description	See page	QT
01	0503010002	1800 GREASE FITTING		02
02	0503010043	PACKING 3750-3250		02
03	0503010314	GASKET		01
04	0503010319	D-2125 SCRAPER		01
05	0503010338	2-342 N 3006-9B O'RING		01
06	0503010345	2-218 N 3006-9B O'RING		01
07	0503010817	1.1/4" SELF LOCKING NUT		01
08	0503010973	W2-2500-500 PK O'RING G.E		01
09	0503010994	W2-4000-500 PK RING G.E		01
10	0503011061	8-342 BACK-UP RING		01
11	0503030384	PLUG N-001		02
12	0531062835	EXTENDER 53.98 X 609		01
13	0511062253	CYLINDER CASE		01
14	0502011969	53,98 X 101,60 PISTON		01
15	0502010017	4" LID		01
16	0502011250	RING OF SUPPORT		01

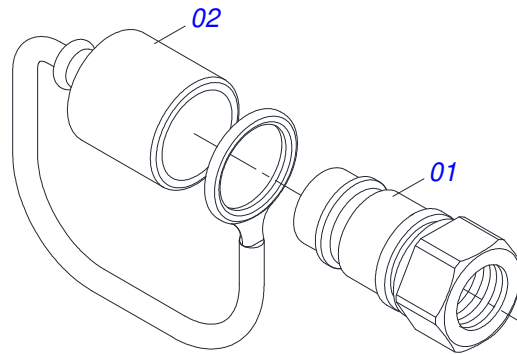

Item	Code	Description	See page	QT
01	0503011627	MALE QUICK COUPLER AGR 1/2 NPT		01
02	0503011882	MALE QUICK COUPLER CAP		01



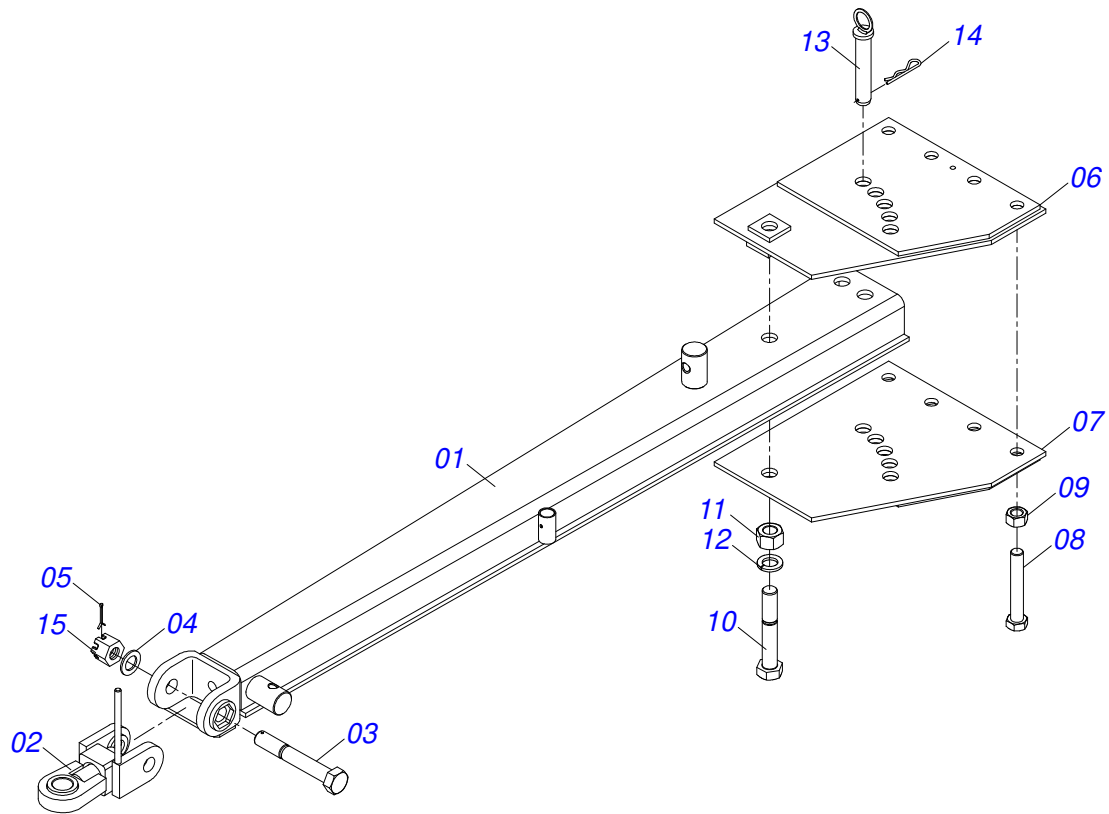

Item	Code	Description	See page	QT
01	0511060300	DRAWBAR		01
02	0521068888	TRACTOR HITCH BODY		01
03	0521013739	BOLT HARNESS		01
04	0501812916	FLAT WASHER		01
05	0503010067	3/16" X 2.1/2" SPLIT PIN		01
06	0511060301	PLATE HITCH		01
07	0511060302	PLATE HITCH		01
08	0503012192	1-1/4" X 8 BOLT		04
09	0503012181	1.1/4" NUT		04
10	0503012258	1-1/2" X 9" BOLT		01
11	0501810110	1.1/2 NC 6FPP NUT		01
12	0503013627	1.1/2 SPRING WASHER		01
13	0511060146	PIN FIXER		01
14	0503031479	STAPLE		01
15	0502011592	CASTLE NUT		01

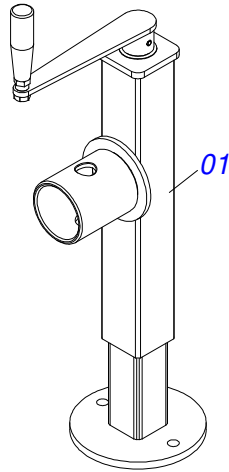

Item	Code	Description	See page	QT
01	0503062227	DRAWBAR JACK		01

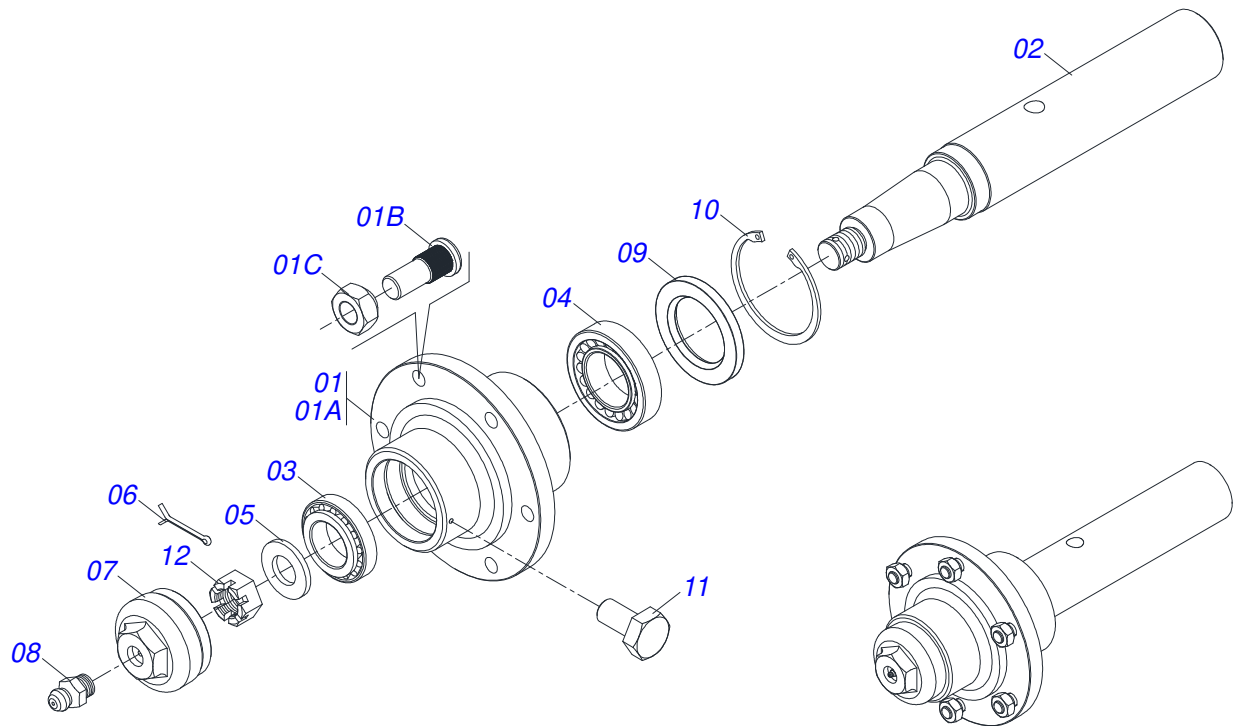

Item	Code	Description	See page	QT
01	0501110766	HUB CARRYING WHEELS WITH BOLT		01
01A	0502011715	WHEEL HUB		01
01B	0503012307	5/8" X 2" BOLT		06
01C	0503010064	5/8 UNF CONIC NUT		06
02	0541014720	CR 7076205/1/1 AXLE		01
03	0503010006	32210 ROLLER BEARING		01
04	0503010005	32212 ROLLER BEARING		01
05	0501010086	FLAT WASHER		01
06	0503010067	3/16" X 2.1/2" SPLIT PIN		01
07	0502011647	COVER		01
08	0503010691	1/4" GREASE FITTING		01
09	0503010009	RETAINER 00573-B		01
10	0503012723	502115 RENO RING		01
11	0503010298	1/4" X 1/2" BOLT		01
12	0503012457	UNF 1.1/4" CASTLE NUT		01

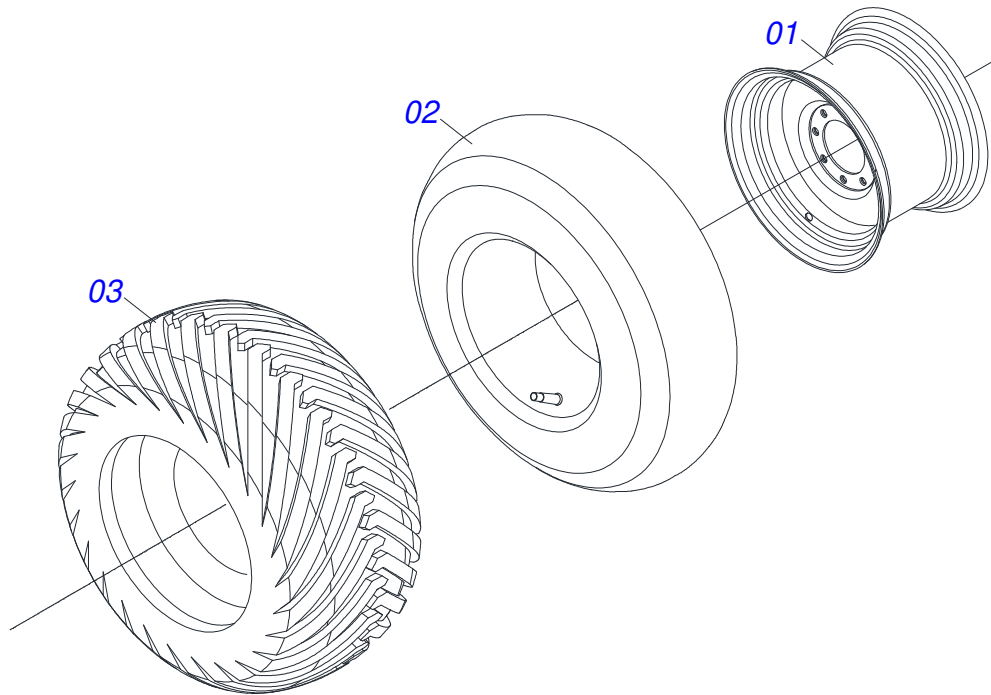

Item	Code	Description	See page	QT
01	0503012916	W-13 X 16,5 HOOP WHEEL		01
02	0503012112	400/60 - 15.5 TR 15 INNER TIRE		01
03	0503013119	CANVAS TIRE 400/60-15,5-T404-14L TRELEBORG		01

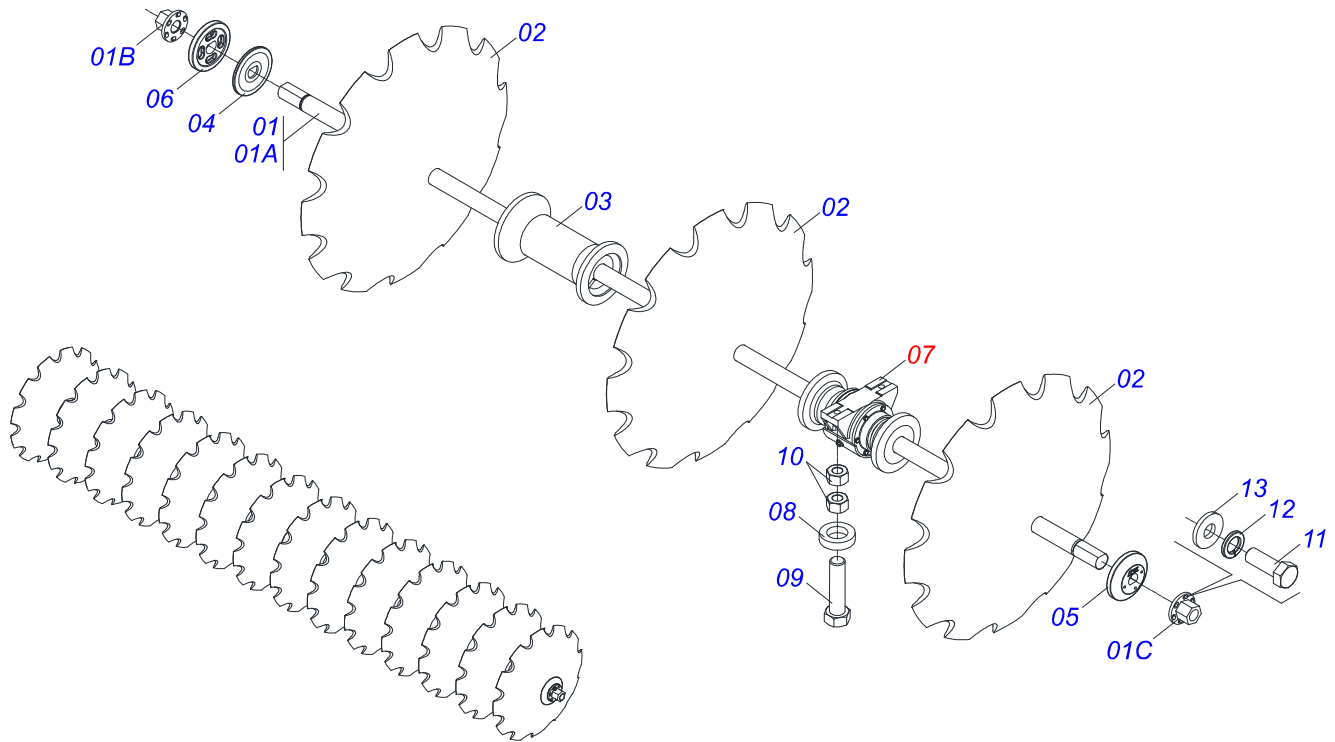

Item	Code	Description	See page	QT
01	0511050179	DISC AXLE 2" UNC X 2405 WITH NUT		04
01A	0521013683	DISC AXLE		01
01B	0502011580	RIGHT NUT		01
01C	0502011581	LEFT NUT		01
02	0602046009	34 X 9 MM NOTCHED DISC		28
03	0502011579	SPACER		12
04	0521013670	CHUCK		04
05	0502011577	OUTER FLANGE		04
06	0502011578	INNER FLANGE		04
07	0501048557	BEARING OIL	10	12
08	0521013709	REINFORCING WASHER		30
09	0503013826	3/4" UNC X 3.3/4" C S G.8 SCREW		24
10	0503012183	SNC 3/4" ZIN 1K03097 NUT		48
11	0503010834	1/2 X 1 BOLT		16
12	0503010019	1/2" SPRING WASHER		16
13	0501010937	13,50 X 28 X 3,00 FLAT WASHER		16

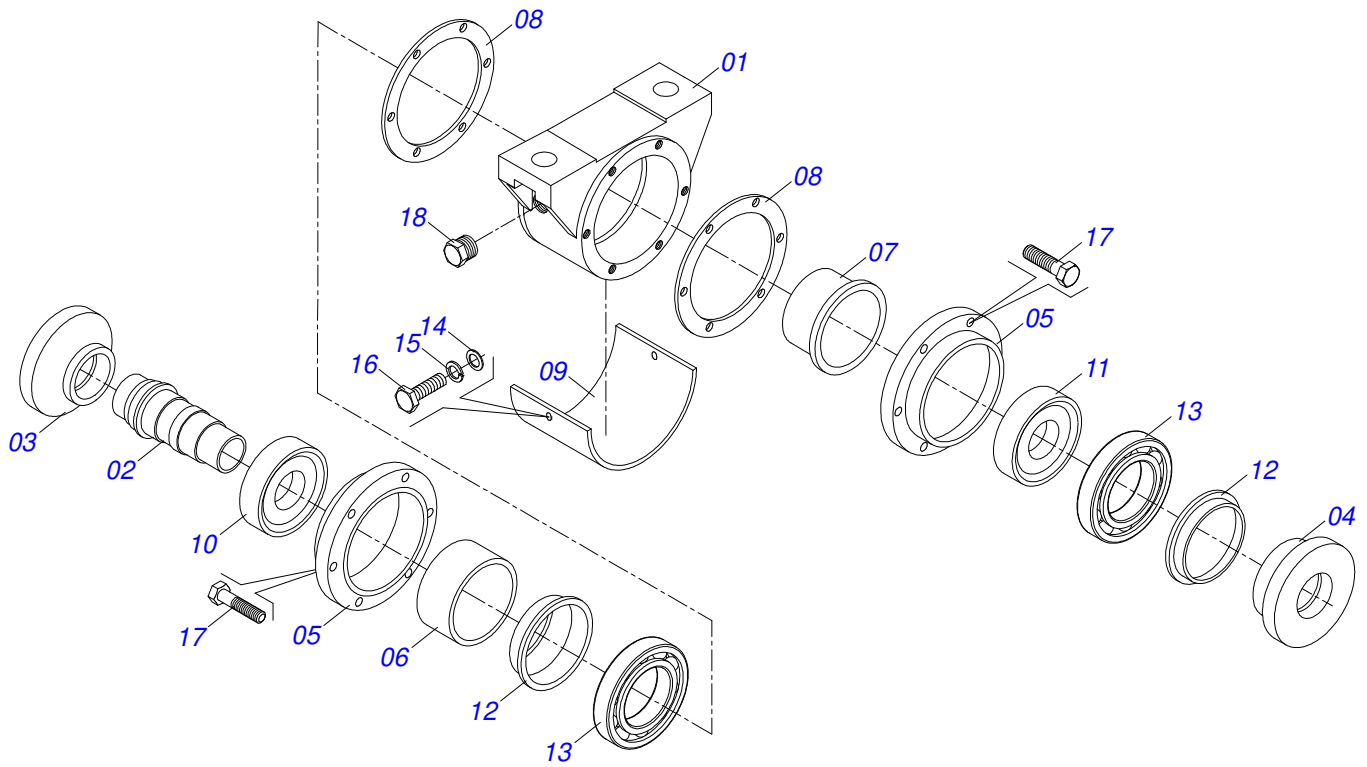

Item	Code	Description	See page	QT
01	0502011641	BEARIN BODY		01
02	0502011633	CENTER DEARIN		01
03	0502011630	WASHER CONCAVE		01
04	0502011631	WASHER CONVEX		01
05	0502011632	BEARING COVER		02
06	0502011827	SPACER		01
07	0502011629	SPACER		01
08	0503031502	JOINT BEARIN		02
09	0521013855	PLATE PROTECTION		01
10	0502011627	HOUSING RETAINE		01
11	0502011628	HOUSING RETAINE		01
12	0503012824	RETAINER		02
13	0503012285	32212 ROLLER BEARING		02
14	0501010984	10,50 X 27 X 3,00 FLAT WASHER		02
15	0503010025	3/8" SPRING WASHER		02
16	0503011334	3/8 UNC X 3/4 CS G.5 ZN BOLT		02
17	0503010237	3/8" X 1" BOLT		12
18	0503010856	OIL PLUG R 3/8 BSPT		01





# ***civemasa***

**Technical Publications | Elaboration and Revision**  
LUIZ CANDIDO

[www.civemasa.com.br](http://www.civemasa.com.br)

